

### Dimensions: [mm]

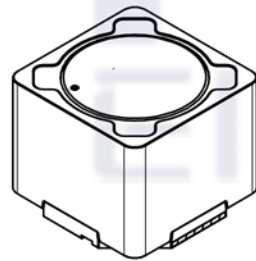

Scale - 2:1

### Recommended Land Pattern: [mm]

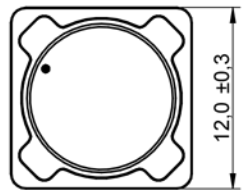
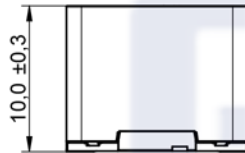
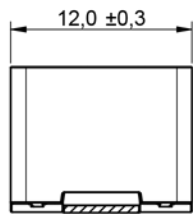
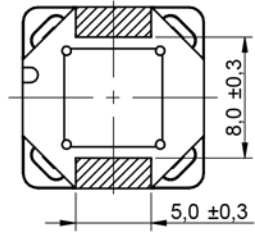
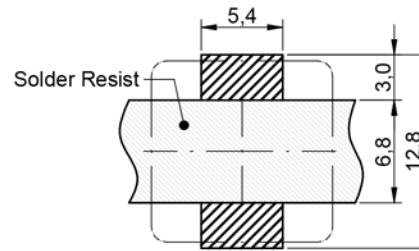

No vias and traces in restricted area

Scale - 2:1

### Schematic:



### Electrical Properties:

Properties		Test conditions	Value	Unit	Tol.
Inductance	L	100 kHz/ 250 mV	330	μH	±20%
Rated Current	I <sub>R</sub>	ΔT = 40 K	1.2	A	max.
Saturation Current	I <sub>SAT</sub>	ΔL/L < 10 %	1.3	A	typ.
DC Resistance	R <sub>DC</sub>	@ 20 °C	340	mΩ	typ.
DC Resistance	R <sub>DC</sub>	@ 20 °C	408	mΩ	max.
Self Resonant Frequency	f <sub>res</sub>		2.1	MHz	typ.

### Certification:

RoHS Approval	Compliant [ 2011/65/EU&2015/863 ]
REACH Approval	Conform or declared [ (EC)1907/2006 ]
Halogen Free	Conform [ JEDEC JS709B ]
Halogen Free	Conform [ IEC 61249-2-21 ]

### General Properties:

It is recommended that the temperature of the component does not exceed +125 °C under worst case conditions	
Ambient Temperature (referring to I <sub>R</sub> )	-40 up to +85 °C
Operating Temperature	-40 up to +125 °C
Storage Conditions (in original packaging)	< 40 °C ; < 75 % RH
Moisture Sensitivity Level (MSL)	1
Test conditions of Electrical Properties: +20 °C, 33 % RH if not specified differently	
Coplanarity of the terminal pads: 120 μm	

### Product Marking:

Start of Winding	•
Marking	*331 (Inductance Code)



**FKS**  
Electronics



Shaanxi FKS Electronic Parts Import&Export Co.,Ltd.  
Address:Building B1,The West Cloud Valley, Fengxi New City  
Xixian New Area,Xianyang City,Shaanxi Province,China.  
Tel:0086 29 8868 5333 Fax:0086 29 8868 0913  
[Http://www.fks-tech.com](http://www.fks-tech.com)

DATE (YYYY-MM-DD)	2019-02-15	GENERAL TOLERANCE	DIN ISO 2768-1m	PROJECTION METHOD	
DESCRIPTION		<b>SMT Shielded Power Inductor</b>		ORDER CODE	
				FKS7847709331	
SIZE/TYPE	1210	STATUS	Valid		

**Typical Inductance vs. Current Characteristics:**

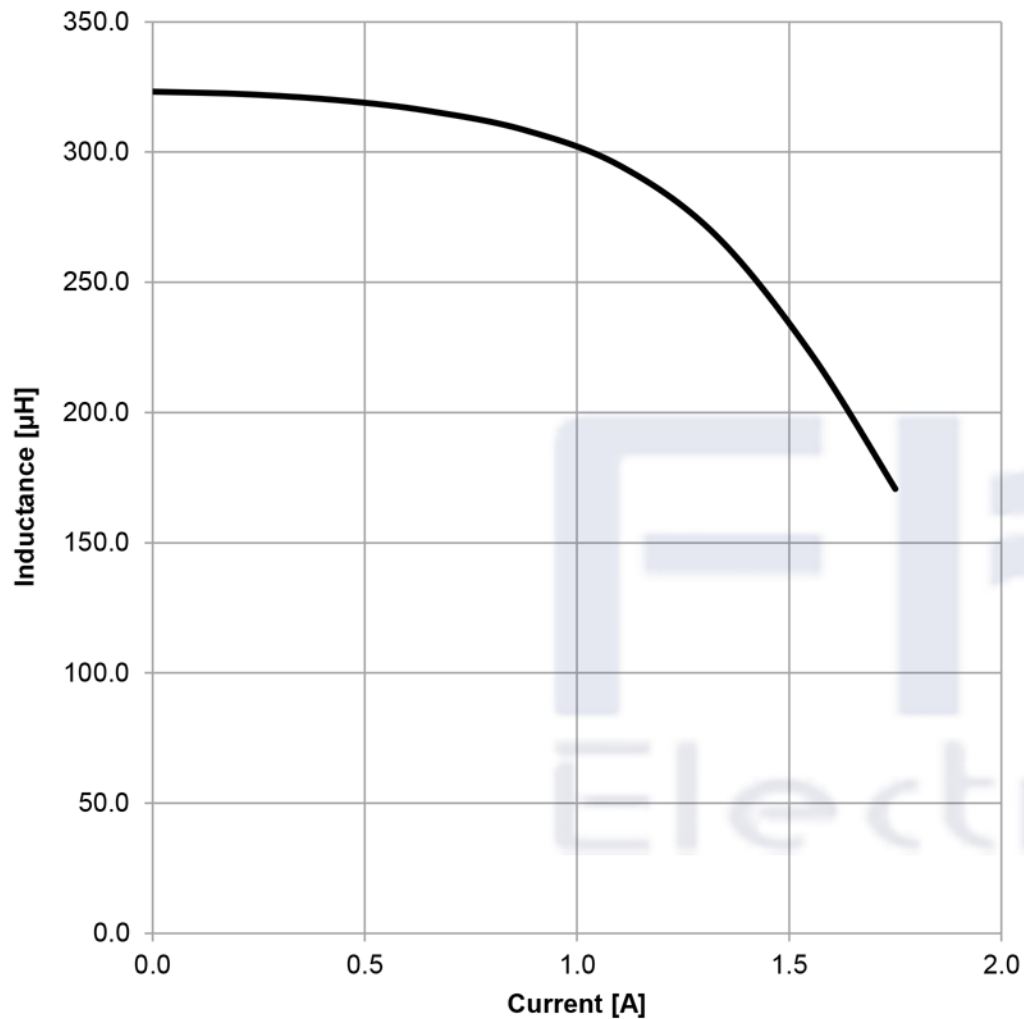

**Typical Temperature Rise vs. Current Characteristics:**

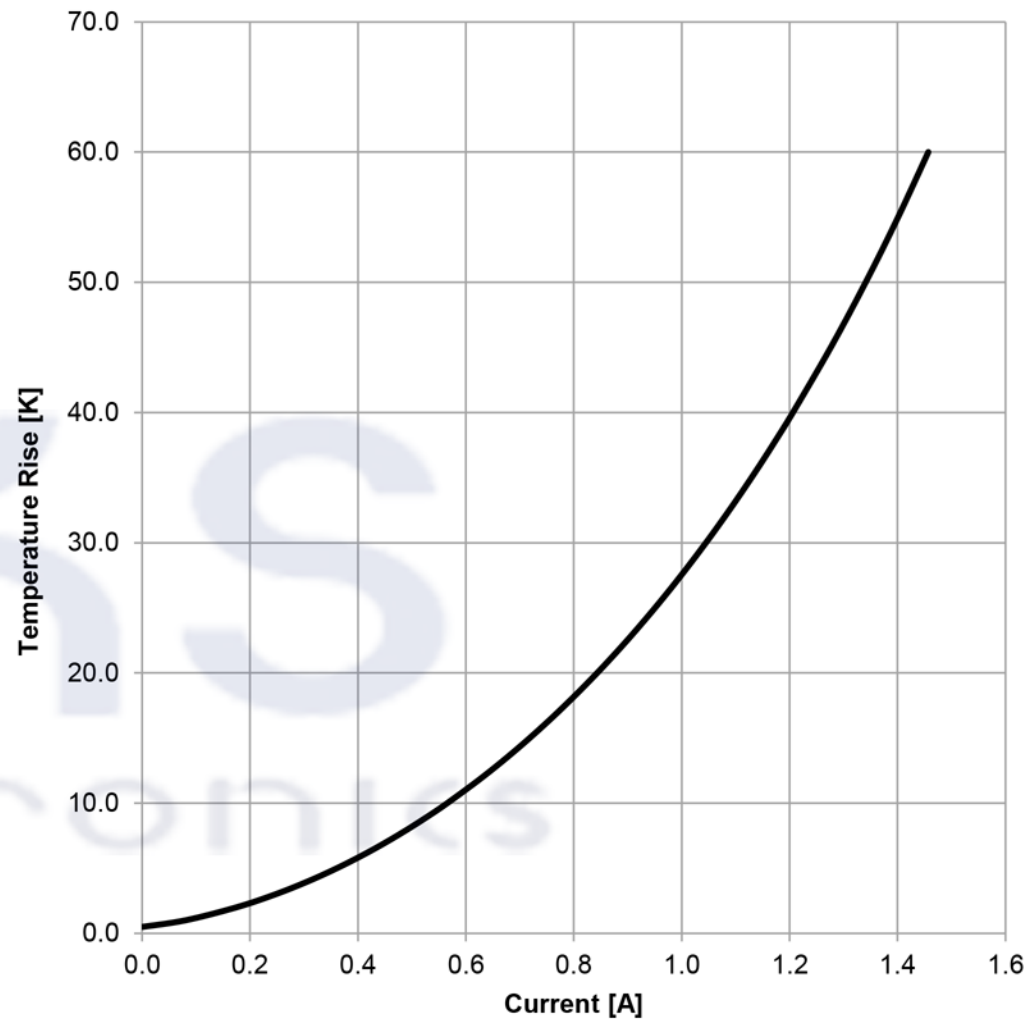

**FKS**  
Electronics



Shaanxi FKS Electronic Parts Import&Export Co.,Ltd.  
Address: Building B1, The West Cloud Valley, Fengxi New City  
Xixian New Area, Xianyang City, Shaanxi Province, China.  
Tel: 0086 29 8868 5333 Fax: 0086 29 8868 0913  
[Http://www.fks-tech.com](http://www.fks-tech.com)

DATE (YYYY-MM-DD)  
2019-02-15

GENERAL TOLERANCE  
DIN ISO 2768-1m

PROJECTION METHOD



DESCRIPTION

**SMT Shielded Power Inductor**

ORDER CODE

**FKS7847709331**

SIZE/TYPE





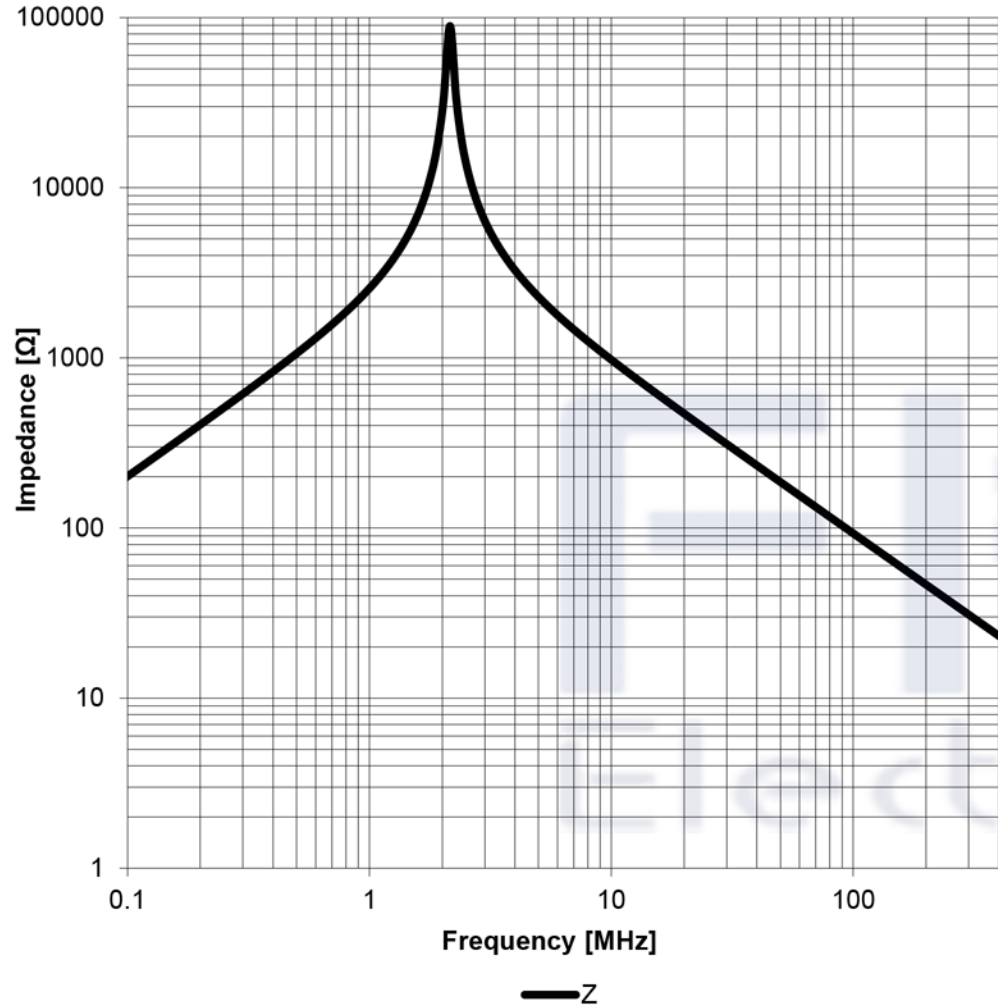

1210

STATUS

Valid

**Typical Impedance Characteristics:**



   	DATE (YYYY-MM-DD) 2019-02-15	GENERAL TOLERANCE DIN ISO 2768-1m	PROJECTION METHOD 
		Shaanxi FKS Electronic Parts Import&Export Co.,Ltd. Address:Building B1,The West Cloud Valley, Fengxi New City Xixian New Area,Xianyang City,Shaanxi Province,China. Tel:0086 29 8868 5333 Fax:0086 29 8868 0913 <a href="http://www.fks-tech.com">Http://www.fks-tech.com</a>	
DESCRIPTION <b>SMT Shielded Power Inductor</b>		ORDER CODE <b>FKS7847709331</b>	
SIZE/TYPE 1210		STATUS Valid	

# Packaging Specification - Tape and Reel: [mm]

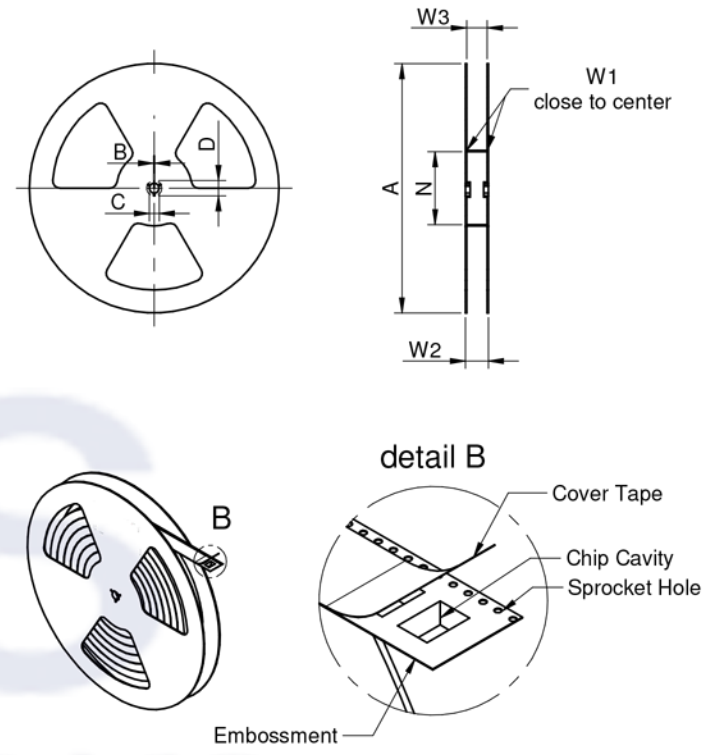
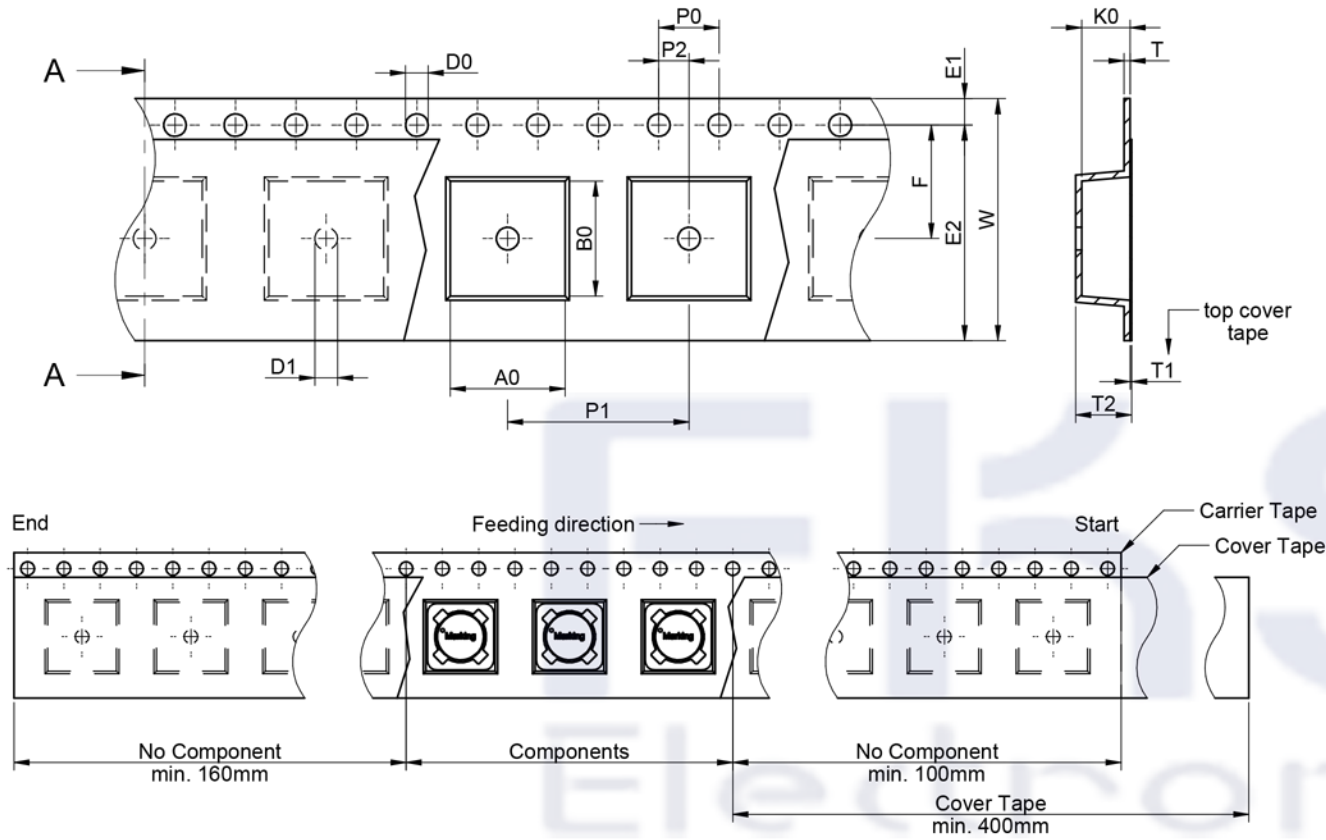

packaging is referred to the international standard IEC 60286-3:2013

	A0	B0	W	T	T1	T2	K0	P0	P1	P2	D0	D1	E1	E2	F	Tape Type 2a	VPE / packaging unit	
tolerance	typ.	typ.	+0,3/-0,1	max.	max.	typ.	typ.	±0,1	±0,1	±0,1	+0,1/-0,0	min.	±0,1	min.	±0,1		pcs.	
size	1210	12,40	12,4	24,0	0,6	0,1	10,9	10,3	4,0	20,0	2,0	1,5	1,5	1,75	22,25	11,5	Polystyrene	250

	A	B	C	D	N	W1	W2	W3	W3	
Tolerance	± 2,0	min.	min.	min.	± 2,0	+ 2	max.	min.	max.	
Tape width	24mm	330,00	1,50	12,90	20,20	60,00	24,40	30,40	23,90	27,40

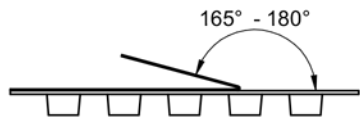

	Pull-of force
Tape width	24 mm
	0,1 N - 1,3 N



Shaanxi FKS Electronic Parts Import&Export Co.,Ltd.  
 Address: Building B1, The West Cloud Valley, Fengxi New City  
 Xixian New Area, Xianyang City, Shaanxi Province, China.  
 Tel: 0086 29 8868 5333 Fax: 0086 29 8868 0913  
[Http://www.fks-tech.com](http://www.fks-tech.com)

DESCRIPTION	DATE (YYYY-MM-DD)	GENERAL TOLERANCE	PROJECTION METHOD
<b>SMT Shielded Power Inductor</b>	2019-02-15	DIN ISO 2768-1m	
ORDER CODE	FKS7847709331		
SIZE/TYPE	1210	STATUS	Valid

### Classification Reflow Profile for SMT components:

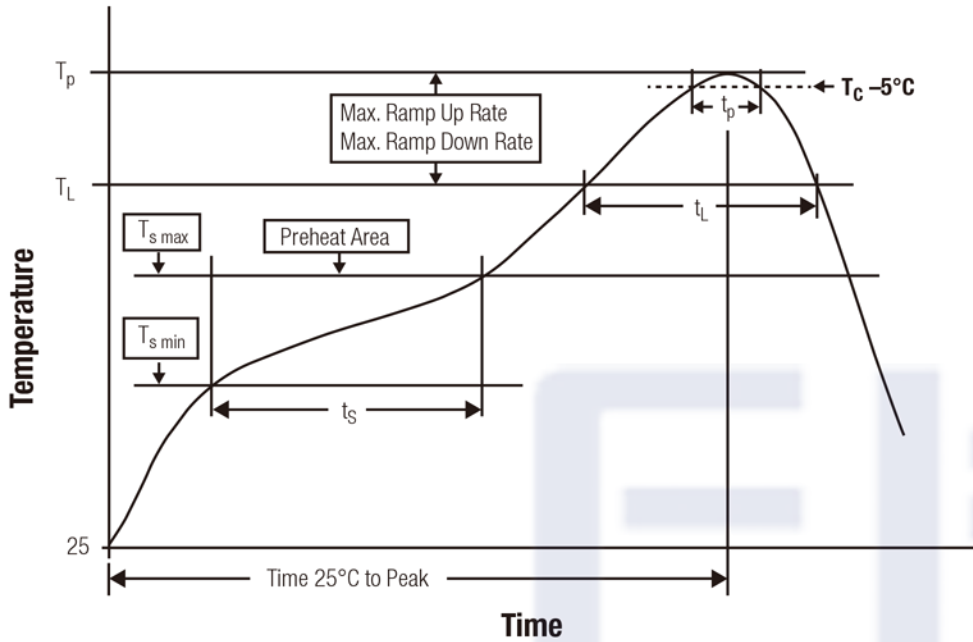

### Classification Reflow Soldering Profile:

Profile Feature		Value
Preheat Temperature Min	$T_{s \text{ min}}$	150 °C
Preheat Temperature Max	$T_{s \text{ max}}$	200 °C
Preheat Time $t_s$ from $T_{s \text{ min}}$ to $T_{s \text{ max}}$	$t_s$	60 - 120 seconds
Ramp-up Rate ( $T_L$ to $T_p$ )		3 °C/ second max.
Liquidous Temperature	$T_L$	217 °C
Time $t_L$ maintained above $T_L$	$t_L$	60 - 150 seconds
Peak package body temperature	$T_p$	see table below
Time within 5°C of actual peak temperature	$t_p$	20 - 30 seconds
Ramp-down Rate ( $T_L$ to $T_p$ )		6 °C/ second max.
Time 25°C to peak temperature		8 minutes max.

refer to IPC/ JEDEC J-STD-020E

### Package Classification Reflow Temperature:

Properties	Volume mm <sup>3</sup> <350	Volume mm <sup>3</sup> 350-2000	Volume mm <sup>3</sup> >2000
PB-Free Assembly   Package Thickness < 1.6 mm	260 °C	260 °C	260 °C
PB-Free Assembly   Package Thickness 1.6 mm - 2.5 mm	260 °C	250 °C	245 °C
PB-Free Assembly   Package Thickness ≥ 2.5 mm	250 °C	245 °C	245 °C
Sn-PB Assembly   Package Thickness < 2.5 mm	235 °C	220 °C	
Sn-PB Assembly   Package Thickness ≥ 2.5 mm	220 °C	220 °C	

refer to IPC/ JEDEC J-STD-020E

		DATE (YYYY-MM-DD) 2019-02-15	GENERAL TOLERANCE DIN ISO 2768-1m	PROJECTION METHOD 
		DESCRIPTION <b>SMT Shielded Power Inductor</b>		ORDER CODE FKS7847709331
				SIZE/TYPE 1210
Shaanxi FKS Electronic Parts Import&Export Co.,Ltd. Address: Building B1, The West Cloud Valley, Fengxi New City Xixian New Area, Xianyang City, Shaanxi Province, China. Tel: 0086 29 8868 5333 Fax: 0086 29 8868 0913 <a href="http://www.fks-tech.com">Http://www.fks-tech.com</a>				