

EFD20

10-Terminal EXT, THT, Horizontal

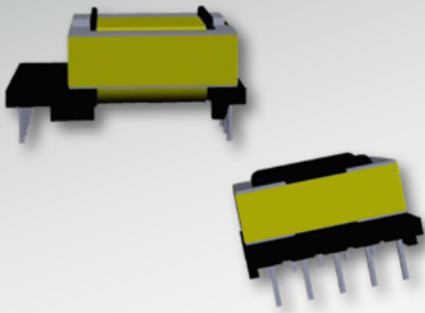

Characteristics

- Through-hole
- Core direction: horizontal
- Reinforced insulation
- Extended rail

Applications

- Offline
- Lighting
- Metering
- PoE
- Industrial controls
- White goods
- Telecom

1

Core Data

Core Part Number	Area (A_c) (mm ²)	Path Length (L_w) (mm)	Volume (V_c) (mm ³)
150-2124	31.00	47.00	1457.00

Bobbin Winding Area

Bobbin Part Number	Width (mm)	Build (mm)	Perimeter (mm)
070-5981	13.40	2.25	31.01

Dimensions & Footprint

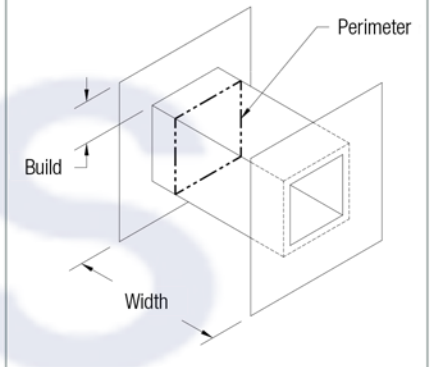
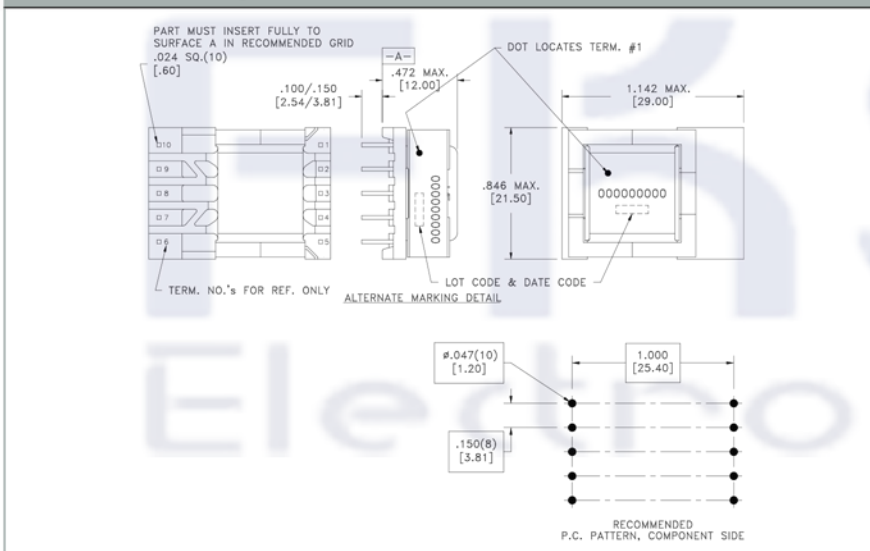

Estimated Maximum Power Level

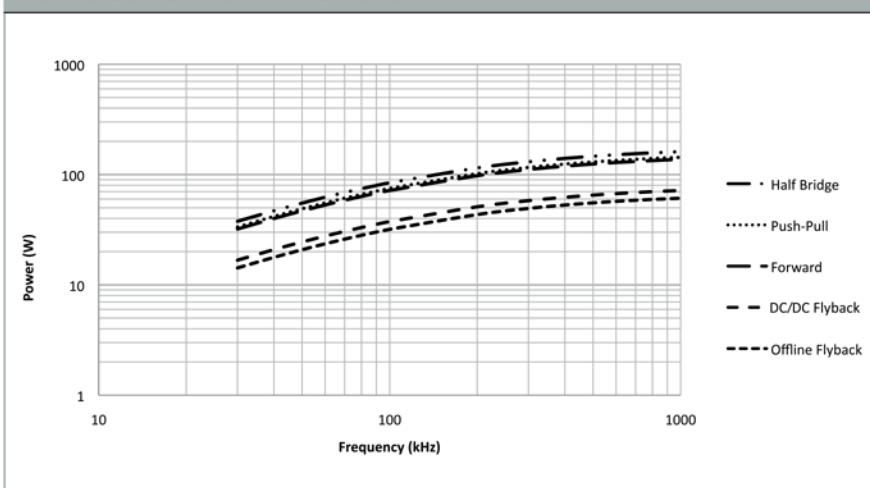

Models

A Altium Library

E Eagle Library

S STEP 3D Model

I IGS 3D Model

W WRL 3D Model