

EFD25

12-Terminal EXT, THT, Horizontal

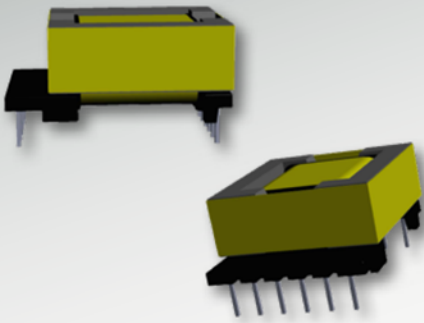

Characteristics

- Through hole
- Core direction: horizontal
- Reinforced insulation
- Extended rail

Applications

- Offline
- Lighting
- Metering
- PoE
- Industrial controls
- White goods
- Telecom

Core Data

Core Part Number	Area (A_c) (mm ²)	Path Length (L_w) (mm)	Volume (V_c) (mm ³)
150-2305	58.00	57.00	3306.00

Bobbin Winding Area

Bobbin Part Number	Width (mm)	Build (mm)	Perimeter (mm)
070-6008	16.61	2.50	39.62

Dimensions & Footprint

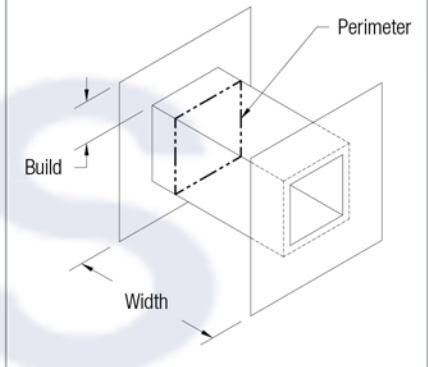
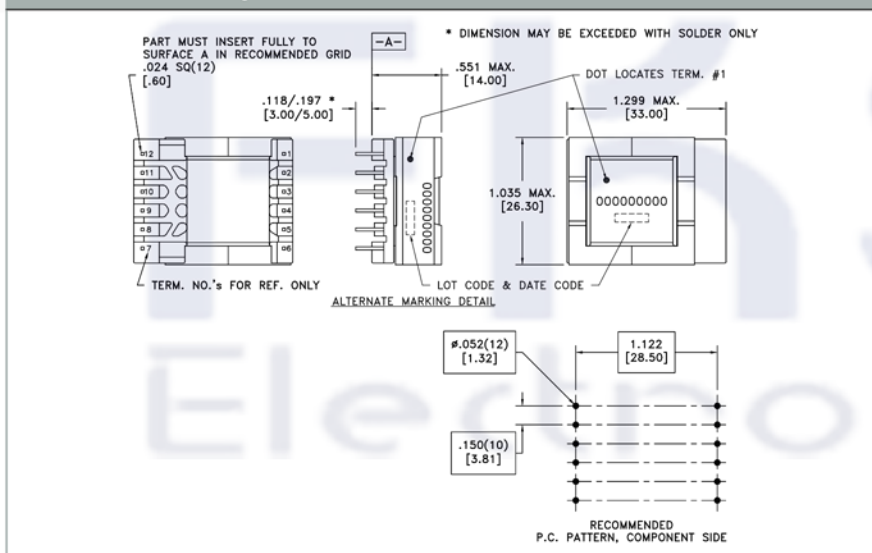

Estimated Maximum Power Level

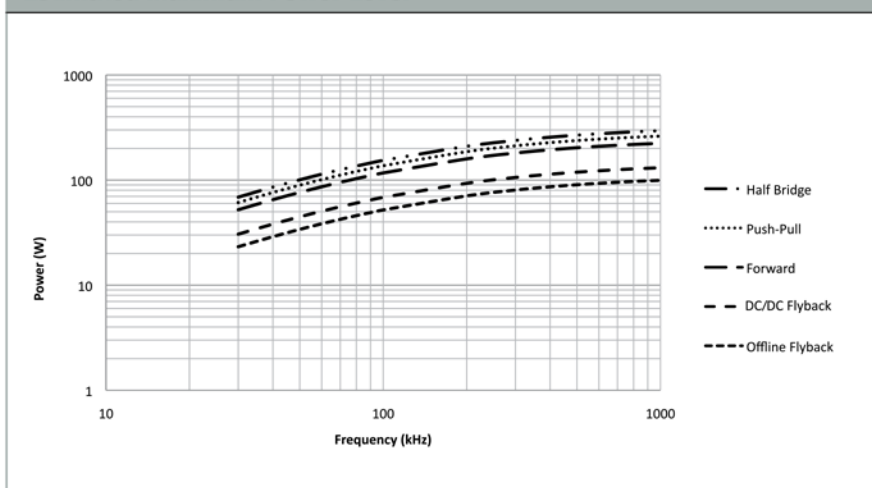

Models

- A** Altium Library
- E** Eagle Library
- S** STEP 3D Model
- I** IGS 3D Model
- W** WRL 3D Model