

Dimensions: [mm]

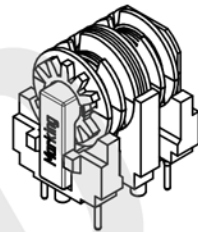
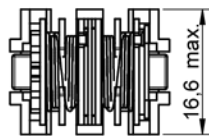
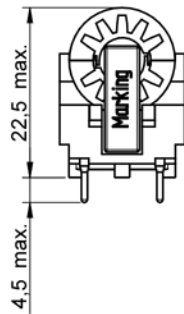
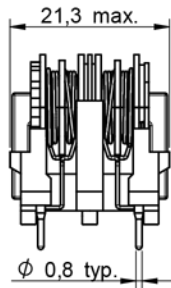
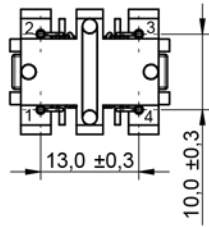

Scale - 1:1

Product Marking:

Marking	7448640406
---------	------------

Recommended Land Pattern: [mm]

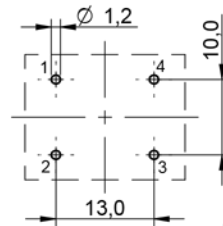

Scale - 1:1

Schematic:



Electrical Properties:

Properties		Test conditions	Value	Unit	Tol.
Number of windings	N		2		
Inductance	L	10 kHz/ 100 mV	0.82	mH	min.
Inductance	L	10 kHz/ 100 mV	1.1	mH	typ.
Rated Current	I_R	@ 70 °C/ $\Delta T < 55 K$	2.65	A	max.
DC Resistance	R_{DC}	@ 20 °C	0.07	Ω	$\pm 15\%$
Rated Voltage	V_R	50 Hz	250	V (AC)	max.
Insulation Test Voltage	V_T	50 Hz/ 5 mA/ 2 sec.	2000	V (AC)	

Certification:

RoHS Approval	Compliant [2011/65/EU&2015/863]
REACH Approval	Conform or declared [(EC)1907/2006]
Component Qualification	AEC-Q200 Grade 1

General Information:

It is recommended that the temperature of the component does not exceed +125 °C under worst case conditions	
Operating Temperature	-40 up to +125 °C
Ambient Temperature (referring to I_R)	-40 up to +70 °C
Storage Conditions (in original packaging)	< 40 °C ; < 75 % RH
Moisture Sensitivity Level (MSL)	1
Temperature Rise < 55 K	
Test conditions of Electrical Properties: +20 °C, 33 % RH if not specified differently	



Shaanxi FKS Electronic Parts Import&Export Co.,Ltd.
 Address: Building B1, The West Cloud Valley, Fengxi New City,
 Xixian New Area, Xianyang City, Shaanxi Province, China.
 Tel: 0086 29 8868 5333 Fax: 0086 29 8868 0913
[Http://www.fks-tech.com](http://www.fks-tech.com)

DATE (YYYY-MM-DD)	2019-11-01	GENERAL TOLERANCE	DIN ISO 2768-1m	PROJECTION METHOD	
DESCRIPTION		Common Mode Power Line Choke		ORDER CODE	
				FKS7448640406	
SIZE/TYPE		UT20V		STATUS	
				Valid from 2019-11-01 due to PCN	

Typical Insertion Loss:

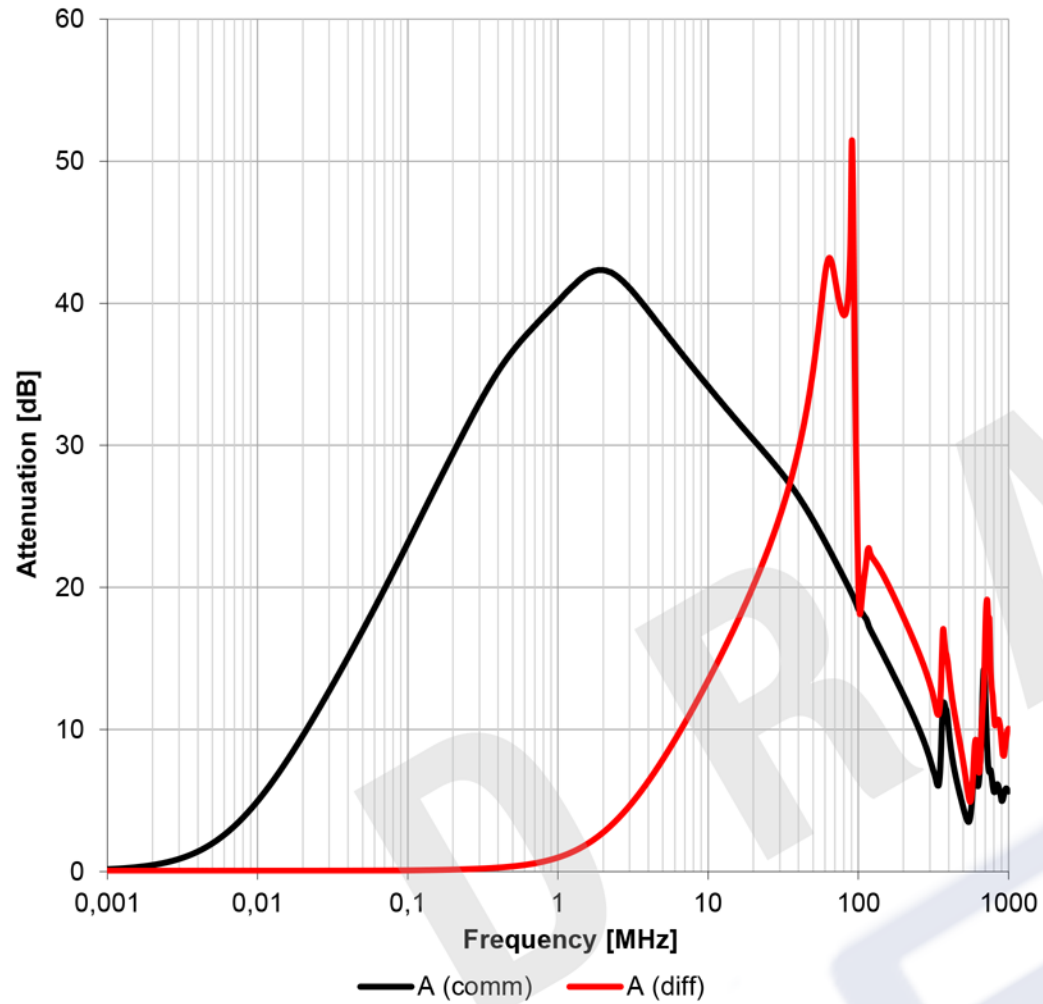

Typical Impedance Characteristics:

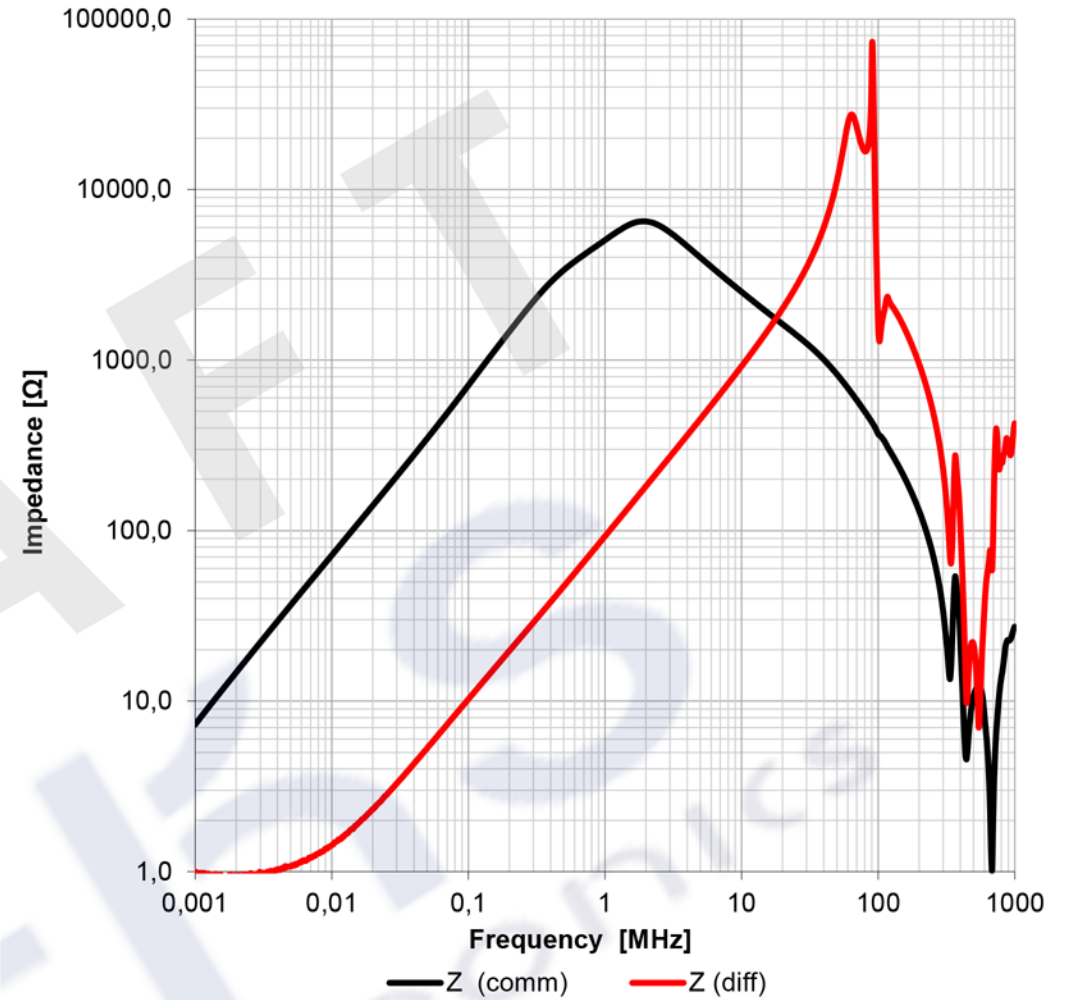

Shaanxi FKS Electronic Parts Import&Export Co.,Ltd.
 Address:Building B1,The West Cloud Valley, Fengxi New City,
 Xixian New Area,Xianyang City,Shaanxi Province,China.
 Tel:0086 29 8868 5333 Fax:0086 29 8868 0913
[Http://www.fks-tech.com](http://www.fks-tech.com)

	DATE (YYYY-MM-DD) 2019-11-01	GENERAL TOLERANCE DIN ISO 2768-1m	PROJECTION METHOD 
DESCRIPTION Common Mode Power Line Choke		ORDER CODE FKS7448640406	
SIZE/TYPE UT20V	STATUS Valid from 2019-11-01 due to PCN		



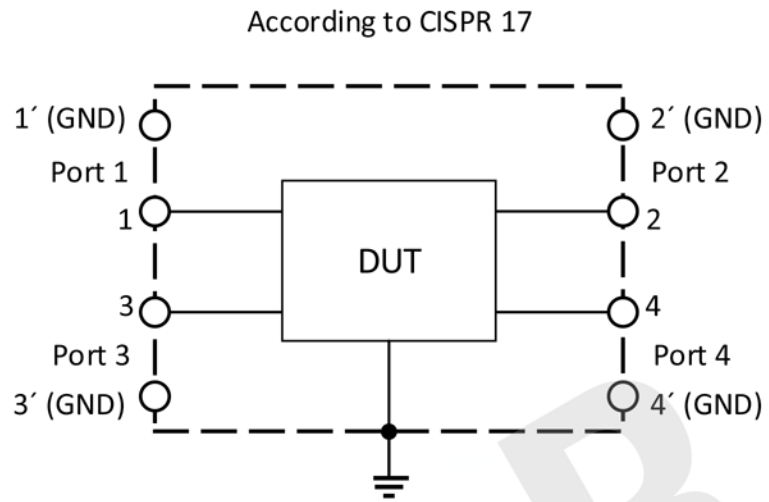



Test Setup:

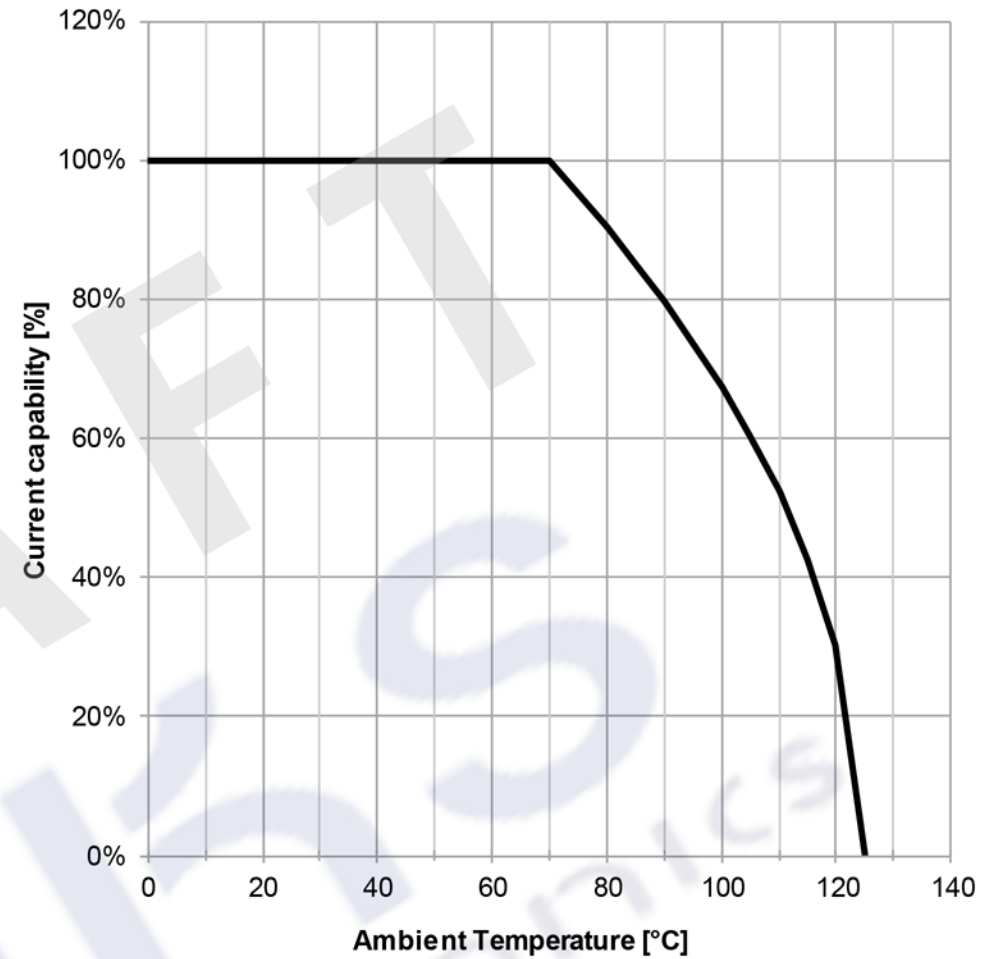

Network Analyzer: Keysight E5080A or equivalent

Derating Curve:



  	DATE (YYYY-MM-DD) 2019-11-01	GENERAL TOLERANCE DIN ISO 2768-1m	PROJECTION METHOD 
	DESCRIPTION Common Mode Power Line Choke		ORDER CODE FKS7448640406
  Shaanxi FKS Electronic Parts Import&Export Co.,Ltd. Address:Building B1,The West Cloud Valley, Fengxi New City, Xixian New Area,Xianyang City,Shaanxi Province,China. Tel:0086 29 8868 5333 Fax:0086 29 8868 0913 Http://www.fks-tech.com	SIZE/TYPE UT20V	STATUS Valid from 2019-11-01 due to PCN	

Packaging Specification - Tray and Carton: [mm]

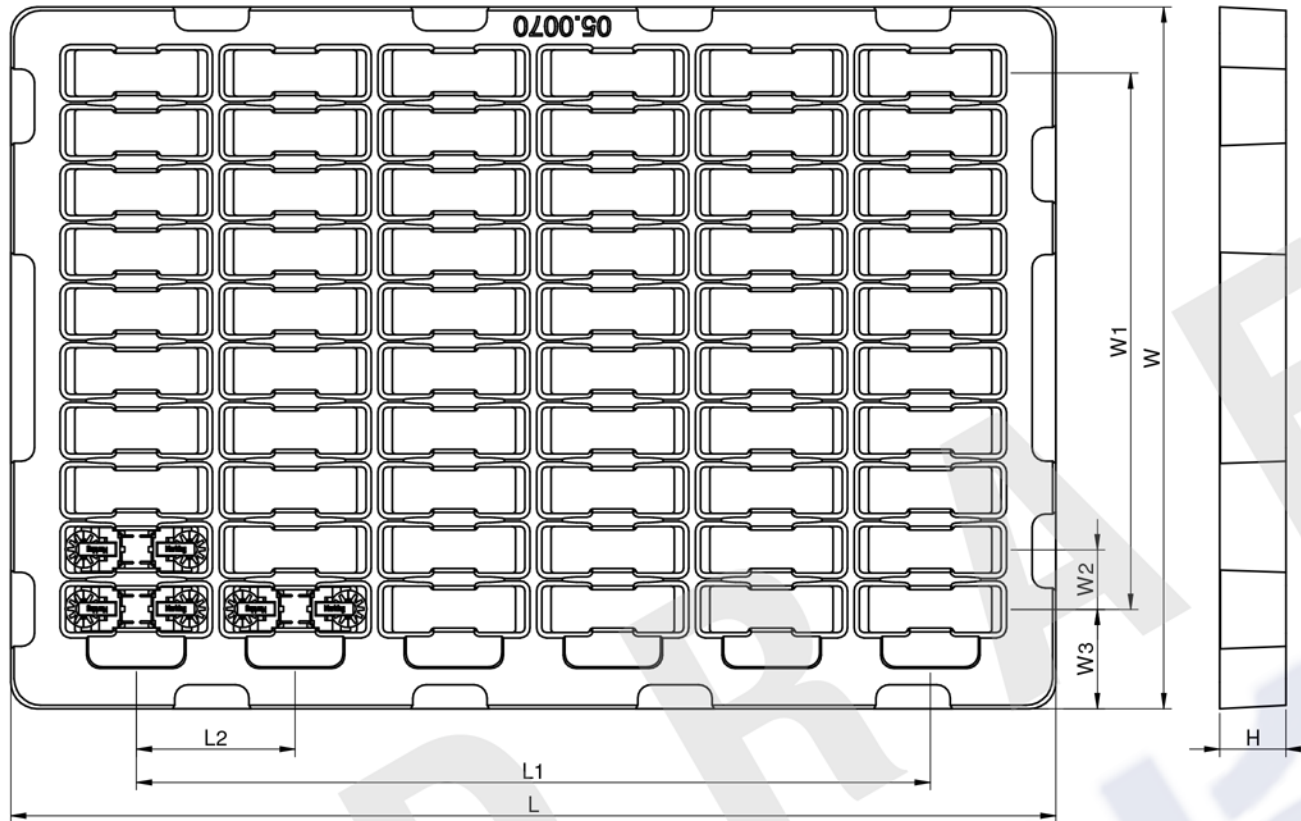

L (mm)	L1 (mm)	L2 (mm)	W (mm)	W1 (mm)	W2 (mm)	W3 (mm)	H (mm)	Qty. (pcs.)	Material
typ.	typ.	typ.	typ.	typ.	typ.	typ.	typ.		
395,00	300,00	60,00	265,00	206,00	22,90	37,50	23,00	120	PS

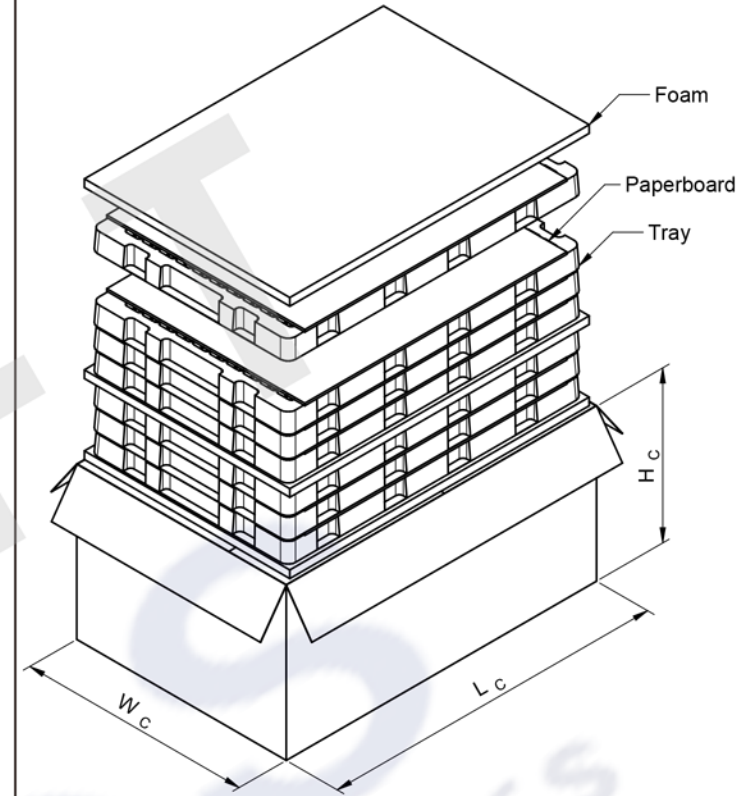

L _c (mm)	W _c (mm)	H _c (mm)	No. of Tray	No. of Paperboard	No. of Foam	Qty. (mm)	Material
typ.	typ.	typ.	pcs.	pcs.	pcs.	pcs.	
415,00	280,00	203,00	7	14	3	840	Paper



Shaanxi FKS Electronic Parts Import&Export Co.,Ltd.
 Address: Building B1, The West Cloud Valley, Fengxi New City,
 Xixian New Area, Xi'an City, Shaanxi Province, China.
 Tel: 0086 29 8868 5333 Fax: 0086 29 8868 0913
[Http://www.fks-tech.com](http://www.fks-tech.com)

DESCRIPTION	DATE (YYYY-MM-DD)	GENERAL TOLERANCE	PROJECTION METHOD
Common Mode Power Line Choke	2019-11-01	DIN ISO 2768-1m	
	ORDER CODE FKS7448640406		
SIZE/TYPE UT20V	STATUS Valid from 2019-11-01 due to PCN		

Classification Wave Soldering Profile:

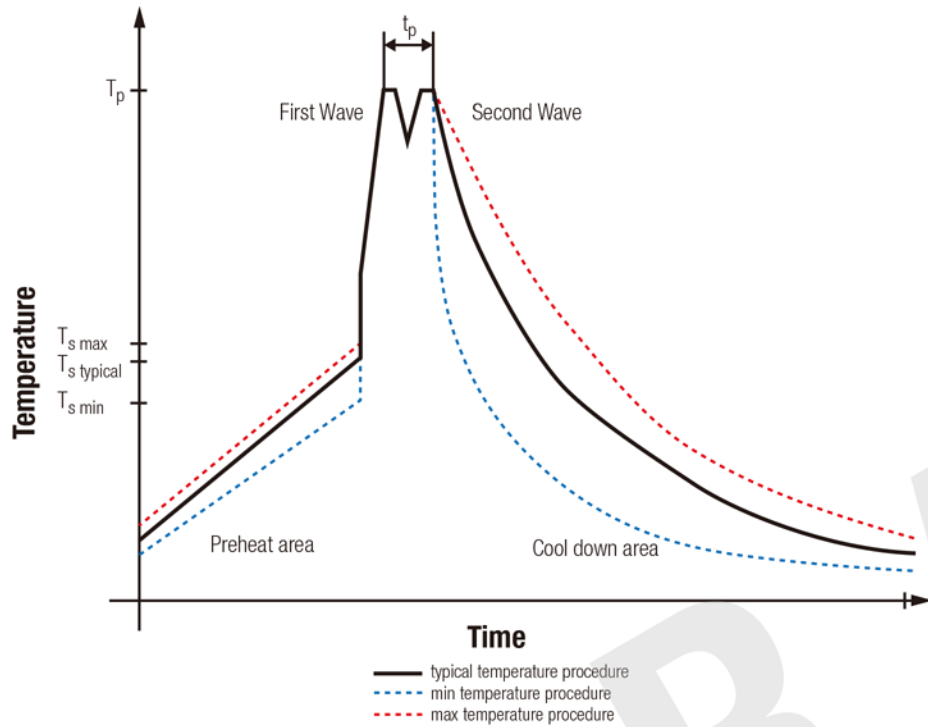

Classification Wave Soldering Profile:

Profile Feature		Pb-Free Assembly	Sn-Pb Assembly
Preheat Temperature Min	$T_{s\ min}$	100 °C	100 °C
Preheat Temperature Typical	$T_{s\ typical}$	120 °C	120 °C
Preheat Temperature Max	$T_{s\ max}$	130 °C	130 °C
Preheat Time t_s from $T_{s\ min}$ to $T_{s\ max}$	t_s	70 seconds	70 seconds
Ramp-up Rate	ΔT	150 °C max.	150 °C max.
Peak Temperature	T_p	250 °C - 260 °C	235 °C - 260 °C
Time of actual peak temperature	t_p	max. 10 seconds max. 5 seconds each wave	max. 10 seconds max. 5 seconds each wave
Ramp-down Rate, Min		~ 2 K/ second	~ 2 K/ second
Ramp-down Rate, Typical		~ 3.5 K/ second	~ 3.5 K/ second
Ramp-down Rate, Max		~ 5 K/ second	~ 5 K/ second
Time 25 °C to 25 °C		4 minutes	4 minutes

refer to EN61760-1:2006

		DATE (YYYY-MM-DD) 2019-11-01	GENERAL TOLERANCE DIN ISO 2768-1m	PROJECTION METHOD
<p>Shaanxi FKS Electronic Parts Import&Export Co.,Ltd. Address:Building B1,The West Cloud Valley, Fengxi New City, Xixian New Area,Xianyang City,Shaanxi Province,China. Tel:0086 29 8868 5333 Fax:0086 29 8868 0913 Http://www.fks-tech.com</p>		Common Mode Power Line Choke		ORDER CODE FKS7448640406
SIZE/TYPE UT20V		STATUS Valid from 2019-11-01 due to PCN		