

A Dimensions: [mm]

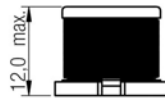
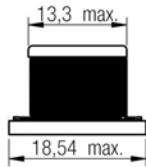
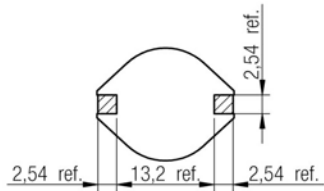

Scale - 1:1

Reference on drawing	Description
•	Start of winding
Marking	302 (Inductance Code)

B Recommended land pattern: [mm]

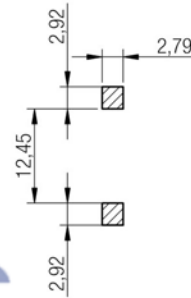

Scale - 2:1



D Electrical Properties:

Properties	Test conditions		Value	Unit	Tol.
Inductance	100 kHz/ 100 mV	L	3.0	mH	± 10%
Capacitance		C	21	pF	ref.
DC Resistance	@ 20°C	R _{DC}	3.5	Ω	max.
DC Resistance	@ 20°C	R _{DC}	2.9	Ω	typ.
Rated current	ΔT = 40K	I _R	0.5	A	max.
Saturation current	IΔL/L < 10%	I _{sat}	1.0	A	typ.
Self resonant frequency		f _{res}	630	kHz	min.

E General information:

It is recommended that the temperature of the part does not exceed 125°C under worst case operating conditions.

- Ambient temperature: -40°C to +85°C (referring to I_R)
- Operating temperature: -40°C to +125°C
- Storage temperature (on tape & reel): -20°C to +40°C; 75% RH max.
- Test conditions of Electrical Properties: 20°C, 33% RH if not specified differently

		Projection		DESCRIPTION	
				SMD Wire Wound Inductor	
2015-07-01					
		Shaanxi FKS Electronic Parts Import&Export Co.,Ltd. FKS(Xi'an) Electronic Technology Co.,Ltd. Address: B1 Building,Western Cloud Valley,Fengxi New Town, Xixian New Area,Xi'an City, Shaanxi Province,China. Tel: +86-29-8868 5333 Fax: +86-29-8868 0913		Order.- No.	
		FKS Electronics		FKS74458303	
DATE				SIZE	
				A4	
				Size: Type L (Actuator)	



G Packaging Specification - Tape and Reel [mm]:

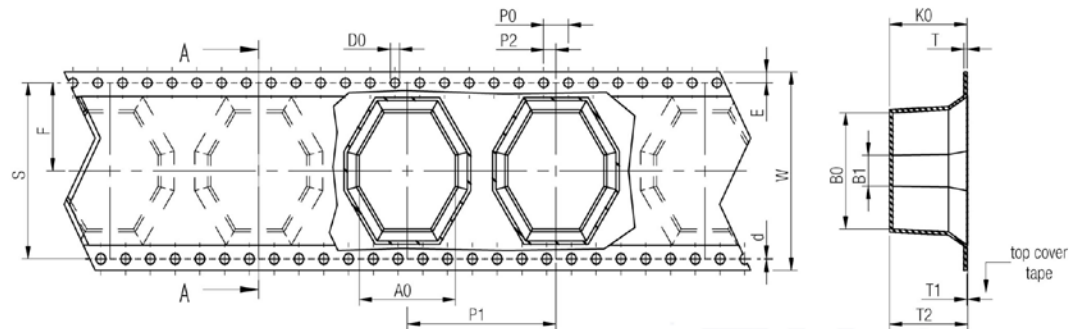

		A0	B0	B1	W	T	T1	T2	K0	d	D0	E	S	F	P0	P1	P2	VPE / packaging unit
tolerance	typ.	typ.	typ.	± 0,3	± 0,05	typ.	max.	typ.	± 0,05	+0,1 -0,0	± 0,1	± 0,1	± 0,1	± 0,1	± 0,1	± 0,1	± 0,1	200
size	7445830x	15,74	19,04	5,00	32,00	0,50	0,10	12,50	12,40	0,20	1,50	1,75	28,40	14,20	4,00	24,00	2,00	200

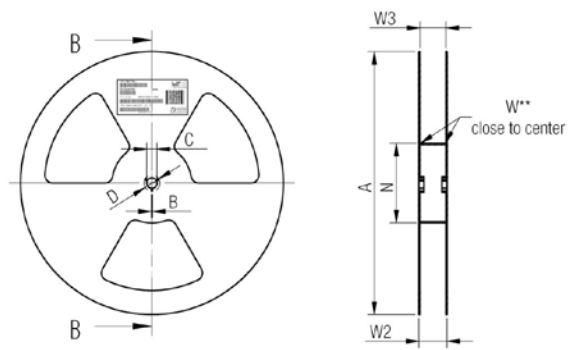

		A	B	C	D	N	W1	W2	W3	W3
tolerance		± 2,0	min.	± 0,8	min.	± 2,0	+ 1,5	max.	min.	max.
Tape width	32 mm	330,00	1,50	13,00	20,20	100,00	32,40	38,40	31,90	35,40

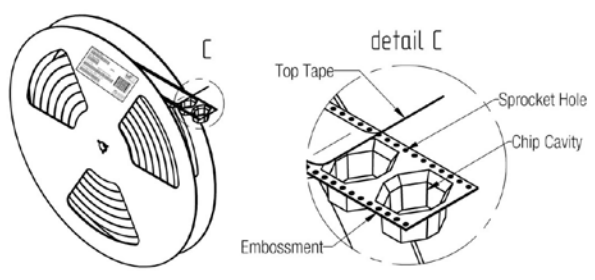
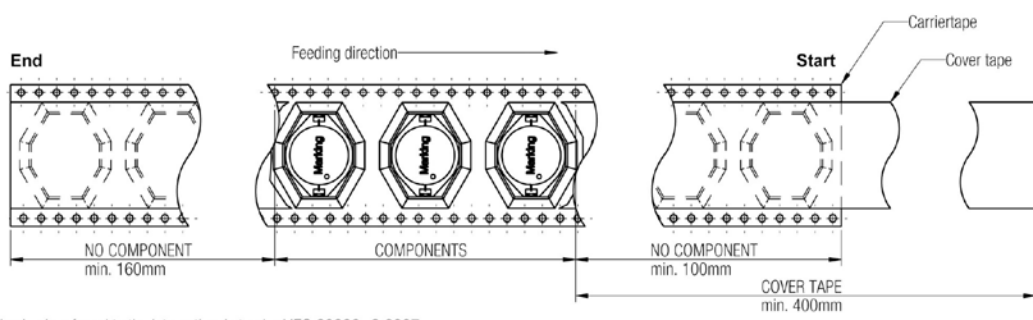

Packaging is referred to the international standard IEC 60286 -3:2007

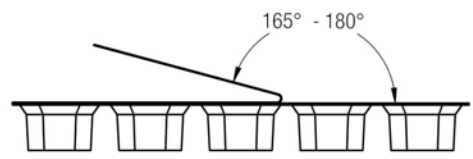

Pull-of force	0,1 N - 1,3 N
Tape width	32 mm

2015-07-01	Projection	
	Shaanxi FKS Electronic Parts Import&Export Co.,Ltd. FKS(Xi'an) Electronic Technology Co.,Ltd. Address: B1 Building,Western Cloud Valley,Fengxi New Town, Xixian New Area,Xi'an City, Shaanxi Province,China. Tel: +86-29-8868 5333 Fax: +86-29-8868 0913	
DATE		

DESCRIPTION		SMD Wire Wound Inductor	
Order.- No.	FKS74458303		SIZE
	Size: Type L (Actuator)		A4

H Soldering Specifications:



H1: Classification Reflow Profile for SMT components:

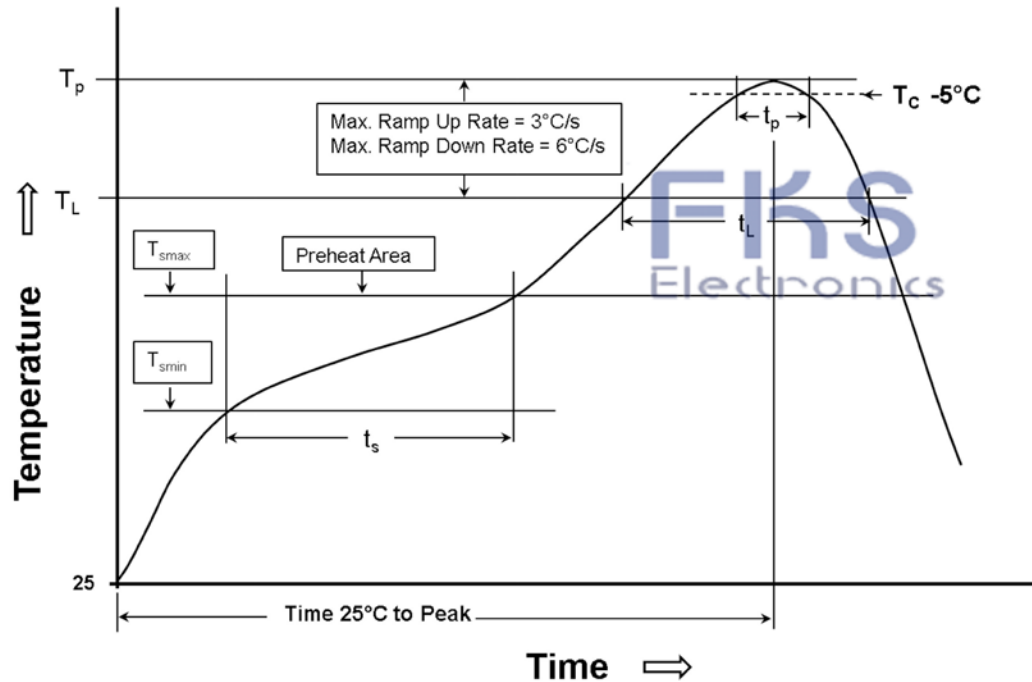

H2: Classification Reflow Profiles

Profile Feature	Pb-Free Assembly
Preheat - Temperature Min (T_{smin}) - Temperature Max (T_{smax}) - Time (t_s) from (T_{smin} to T_{smax})	150°C 200°C 60-120 seconds
Ramp-up rate (T_L to T_p)	3°C/ second max.
Liquidous temperature (T_L) Time (t_L) maintained above T_L	217°C 60-150 seconds
Peak package body temperature (T_p)	See Table H3
Time within 5°C of actual peak temperature (t_p)	20-30 seconds
Ramp-down rate (T_p to T_L)	6°C/ second max.
Time 25°C to peak temperature	8 minutes max.

refer to IPC/JEDEC J-STD-020D

H3: Package Classification Reflow Temperature

	Package Thickness	Volume mm ³ <350	Volume mm ³ 350 - 2000	Volume mm ³ >2000
PB-Free Assembly	< 1.6 mm	260°C	260°C	260°C
PB-Free Assembly	1.6 - 2.5 mm	260°C	250°C	245°C
PB-Free Assembly	≥ 2.5 mm	250°C	245°C	245°C

refer to IPC/JEDEC J-STD-020D

				Projection 	DESCRIPTION
	2015-07-01				FKS SMD Wire Wound Inductor
				Shaanxi FKS Electronic Parts Import&Export Co.,Ltd. FKS(Xi'an) Electronic Technology Co., Ltd. Address: B1 Building,Western Cloud Valley,Fengxi New Town, Xidian New Area,Xi'an City, Shaanxi Province,China. Tel: +86-29-8868 5333 Fax: +86-29-8868 0913	Order.- No. FKS74458303
					SIZE A4
	DATE				Size: Type L (Actuator)