

Characteristics

- Surface mount
- Pick & placeable
- Core direction: horizontal
- Functional insulation

Applications

- Lighting
- Metering
- PoE
- DC/DC converter
- Industrial controls
- White goods
- Telecom

Core Data

Core Part Number	Area (A_c) (mm ²)	Path Length (L_w) (mm)	Volume (V_c) (mm ³)
150-2305	58.00	57.00	3306.00

Bobbin Winding Area

Bobbin Part Number	Width (mm)	Build (mm)	Perimeter (mm)
070-4476	16.70	2.64	39.62

Dimensions & Footprint

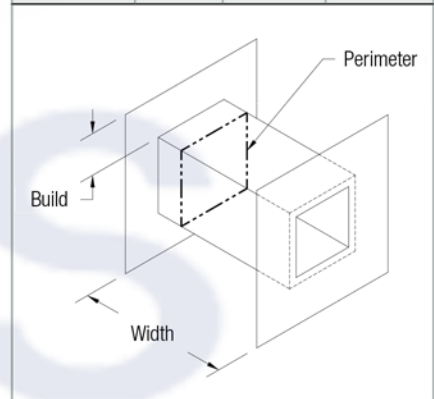
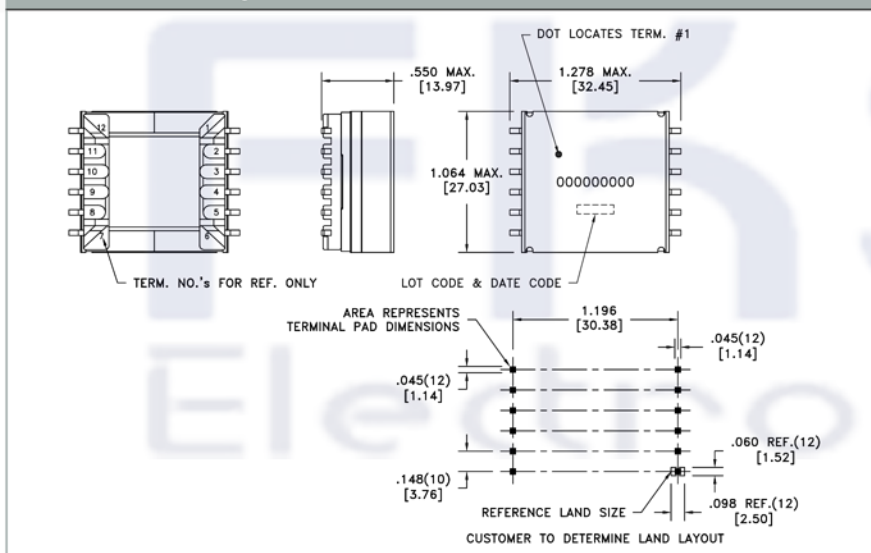

Models

- A** Altium Library
- E** Eagle Library
- S** STEP 3D Model
- I** IGS 3D Model
- W** WRL 3D Model

Estimated Maximum Power Level

