

EFD15

8-Terminal, THT, Horizontal

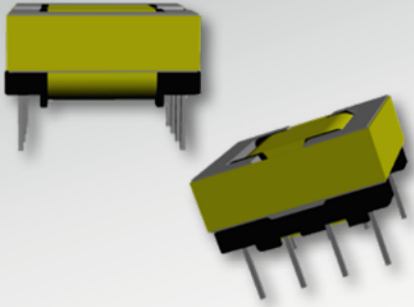

Characteristics

- Through-hole
- Core direction: horizontal
- Functional insulation

Applications

- Lighting
- Metering
- PoE
- DC/DC converter
- Industrial controls
- White goods
- Telecom

Core Data

Core Part Number	Area (A_c) (mm ²)	Path Length (L_w) (mm)	Volume (V_c) (mm ³)
150-2129	15.00	34.00	510.00

Bobbin Winding Area

Bobbin Part Number	Width (mm)	Build (mm)	Perimeter (mm)
070-2745	9.20	1.80	21.01

Dimensions & Footprint

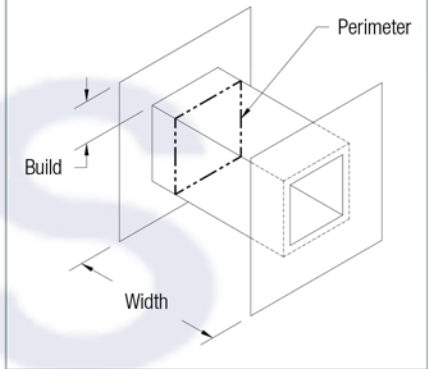
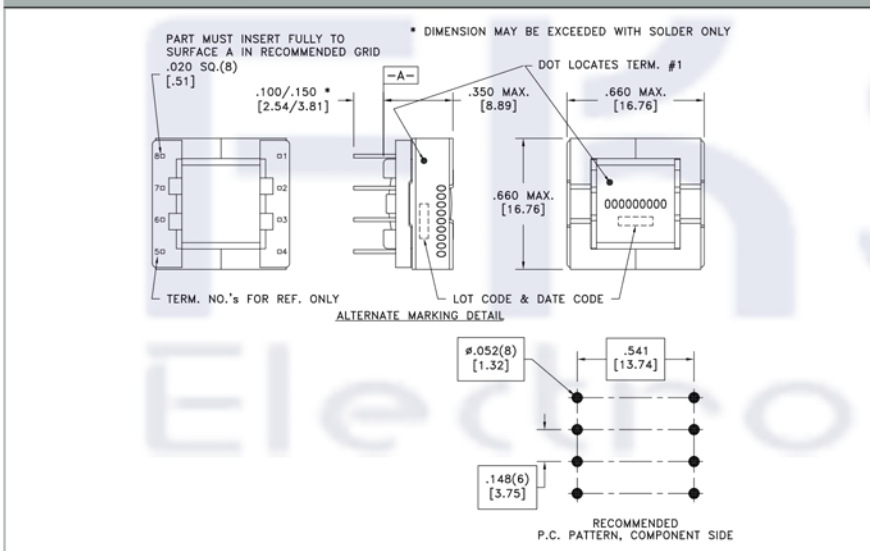

Models

- A** Altium Library
- E** Eagle Library
- S** STEP 3D Model
- I** IGS 3D Model
- W** WRL 3D Model

Estimated Maximum Power Level

