

# EFD20

## 8-Terminal, THT, Horizontal

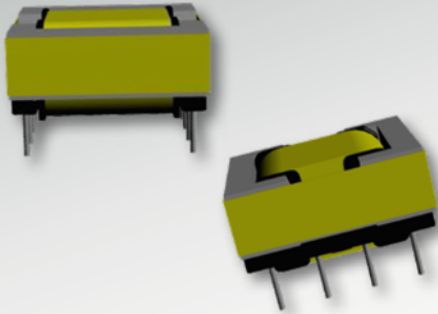

### Characteristics

- Through-hole
- Core direction: horizontal
- Functional insulation

### Applications

- Lighting
- Metering
- PoE
- DC/DC converter
- Industrial controls
- White goods
- Telecom

### Core Data

Core Part Number	Area ( $A_c$ ) (mm <sup>2</sup> )	Path Length ( $L_p$ ) (mm)	Volume ( $V_c$ ) (mm <sup>3</sup> )
150-2124	31.00	47.00	1457.00

### Bobbin Winding Area

Bobbin Part Number	Width (mm)	Build (mm)	Perimeter (mm)
070-2609	13.40	2.08	28.85

### Dimensions & Footprint

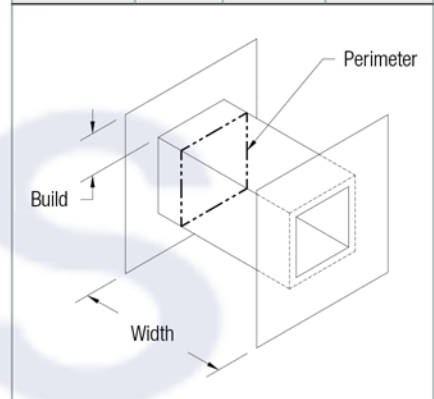
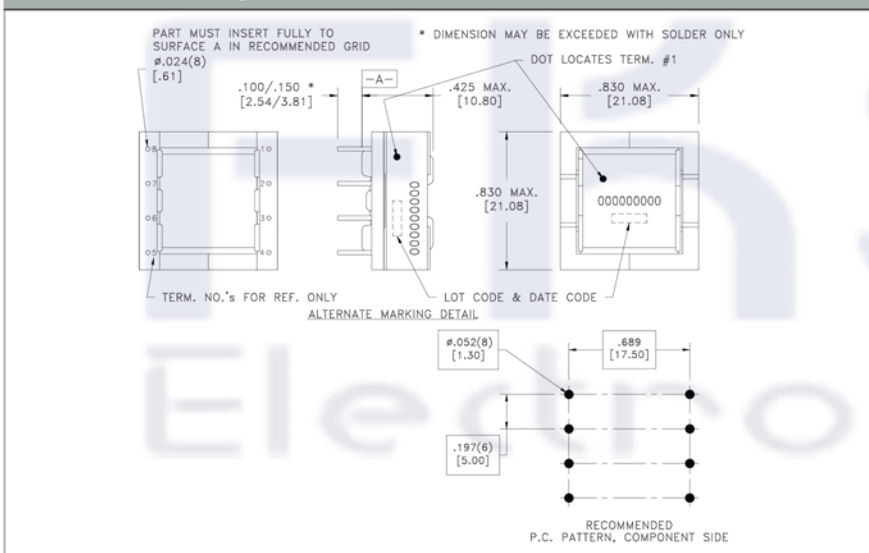

### Models

- A** Altium Library
- E** Eagle Library
- S** STEP 3D Model
- I** IGS 3D Model
- W** WRL 3D Model

### Estimated Maximum Power Level

