

EPW15

15-Terminal EXT, THT, Horizontal

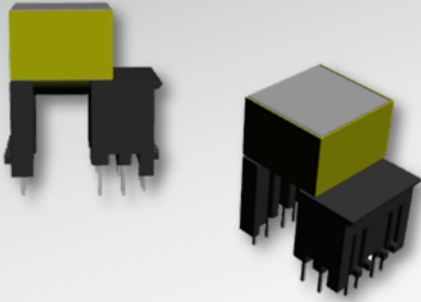

Characteristics

- Through-hole
- Core direction: horizontal
- Reinforced insulation
- Extended rail

Applications

- Offline
- Metering
- POE
- Industrial controls
- White goods
- DSL
- Telecom

Core Data

Core Part Number	Area (A_c) (mm ²)	Path Length (L_w) (mm)	Volume (V_c) (mm ³)
150-2874	26.95	30.61	824.94

Bobbin Winding Area

Bobbin Part Number	Width (mm)	Build (mm)	Perimeter (mm)
070-5996	7.76	2.74	25.10

Dimensions & Footprint

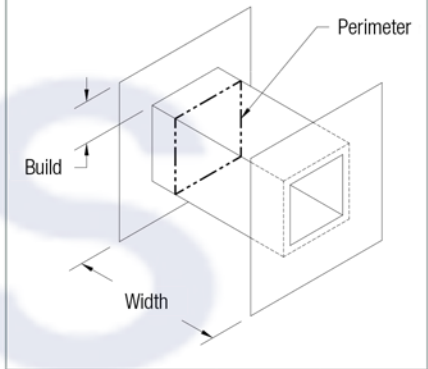
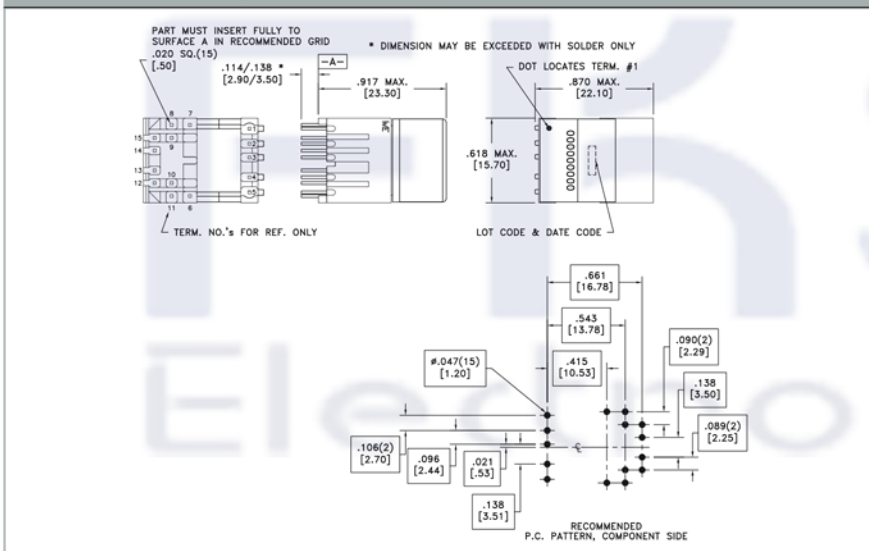

Models

- A** Altium Library
- E** Eagle Library
- S** STEP 3D Model
- I** IGS 3D Model
- W** WRL 3D Model

Estimated Maximum Power Level

